

Humidified micro gas turbine: Flexible power and heat.

This handout presents the activities in the BURN Research Group on humidified gas turbines. The presentation covers the motivation of the research, some experimental results and a detailed analysis of the energy and exergy flows.

wdepaepe@vub.ac.be

mmontero@vub.ac.be

fcontino@vub.ac.be

Humidified micro gas turbine: Flexible power and heat

Marina Montero Carrero, Ward De Paepe,
Svend Bram, Francesco Contino
Vrije Universiteit Brussel

Alessandro Parente
Université Libre de Bruxelles

Why do we still
study mGTs?

Why haven't mGTs
succeeded yet?

Micro Gas Turbines (mGT) in Combined Heat and Power (CHP) applications have been studied for more than 15 years. They are still investigated because they present interesting advantages.

micro Gas Turbines (mGT) have very high Combined Heat and Power efficiencies

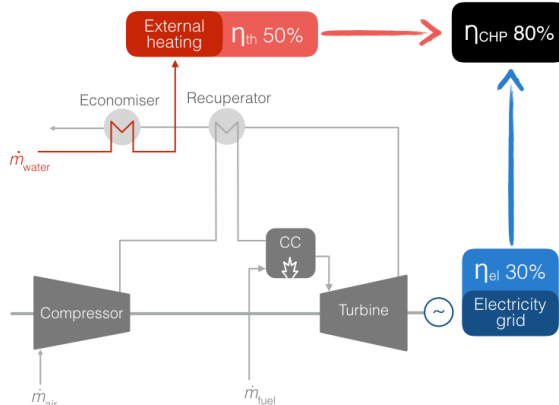

One of these advantages is the high CHP efficiency, combining around 30% electrical efficiency with 50% heat efficiency.

Why do we still study mGTs?

High CHP efficiencies

In comparison to piston engines
lower emissions
only one moving part

Why haven't mGTs succeeded yet?

In addition to this advantage, micro gas turbines are more convenient than piston engines in other aspects, such as: lower emissions and only one moving part leading to less noise and maintenance.

It is difficult to find users with demands that fit the output of mGTs

Average dwelling in San Francisco

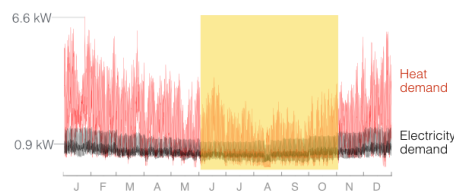

Noble House, large office building in London

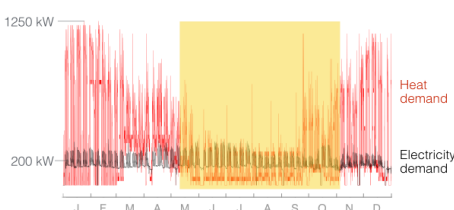

Then, why (despite the above-mentioned advantages) haven't mGTs managed to succeed in the small-scale CHP market?

To understand this, we have to analyse the demand of potential users, such as dwellings or office buildings. As shown in the slide, while the electricity demand remains quite constant during the year, the heat demand strongly fluctuates on a seasonal basis reaching very low values during the summer months.

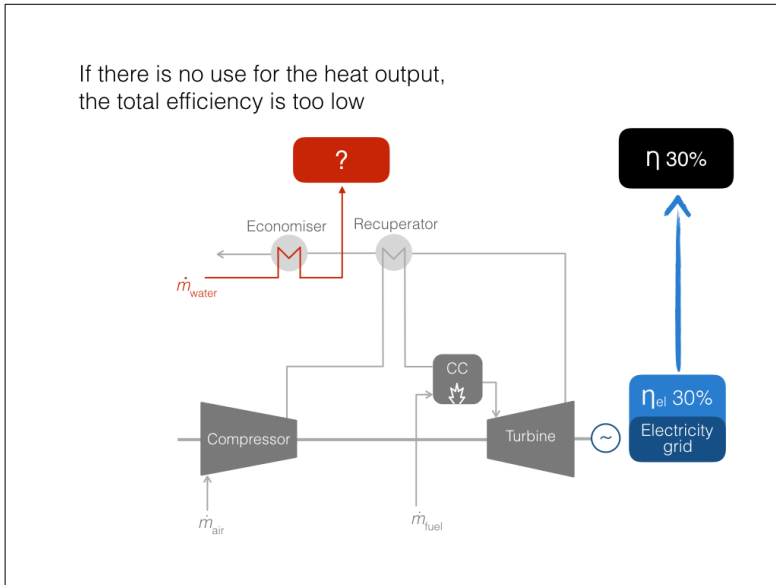

Accordingly, the CHP efficiency of the system decreases significantly. As a result, in such situations, there would be no use for the hot water produced by the mGT. Thus, the overall efficiency is limited to the electrical efficiency (around 30%) which is not high enough for the technology to be competitive.

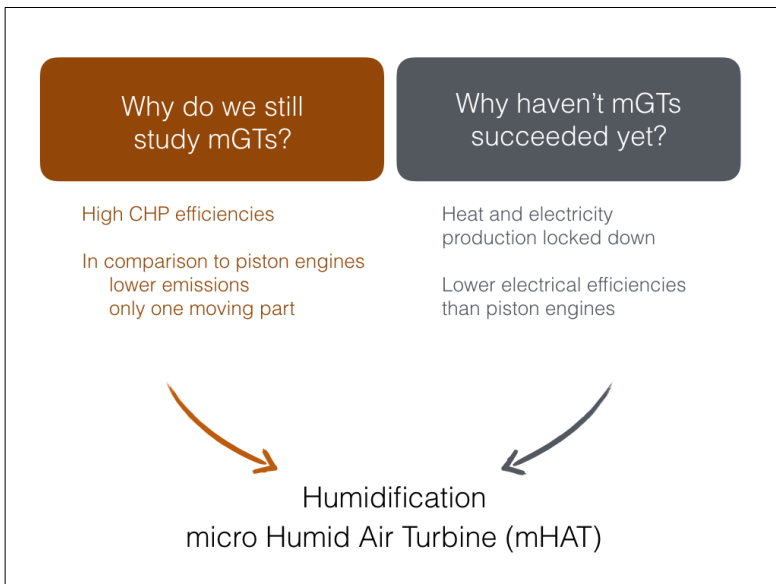

In our research group we still believe in the potential of mGTs. By humidifying the mGT—and transforming it into a micro Humid Air Turbine—we can still make profit of its advantages while addressing its challenges.

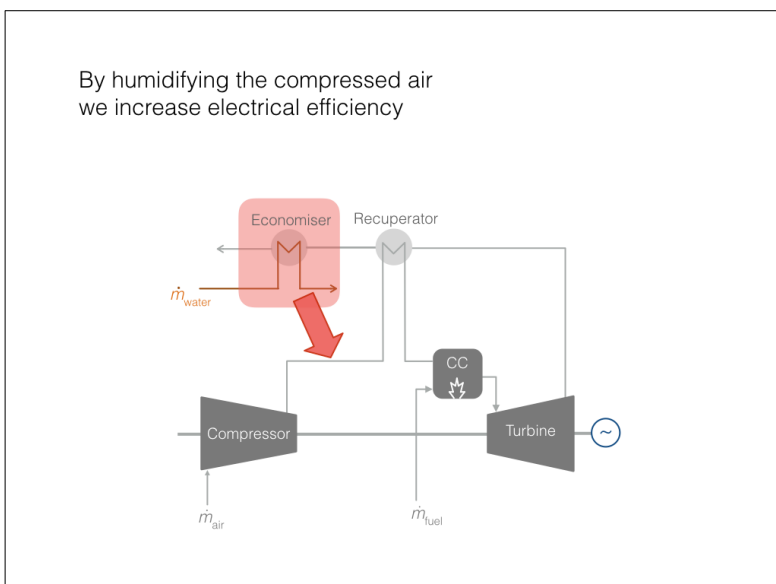

During moments of no heat demand, we can still make use of the heat available in the economiser by injecting it at the back of the compressor.

By humidifying the compressed air we increase electrical efficiency

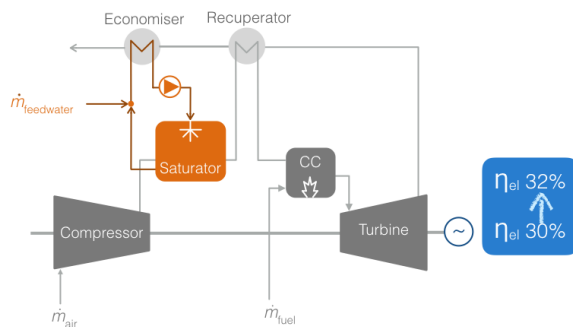

In an mHAT hot water injection takes place in a saturation tower. In order to make up for the evaporated water, feed water is added in the water system. Among other advantages (that will be discussed throughout the presentation) humidification allows increasing the mass flow through the turbine for a given compressor input, which ultimately increases the efficiency.

Whenever possible the mGT should run as CHP

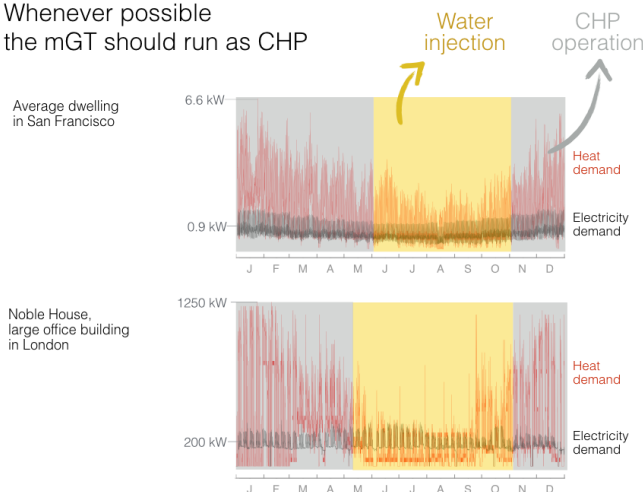

Humidifying the mGT enables increasing the electrical efficiency when there is no heat demand. However, the highest overall efficiencies are still achieved when the mGT is run as a CHP unit. Therefore, it should be operated in CHP mode whenever the heat demand is sufficiently high and in humidified mode whenever this demand is too low and would lead to a machine shutdown without the humidification setup.

The research work is based on the Turbec T100 mGT



Power output:
100 kW_e
165 kW_{th}

Our research activities are based on the mGT T100 model from Turbec, now Ansaldo Energia (AE-T100). The electrical power output is 100 kW and heating output is 165 kW.

A novel spray saturation tower was developed to saturate the compressed air of the T100 at VUB

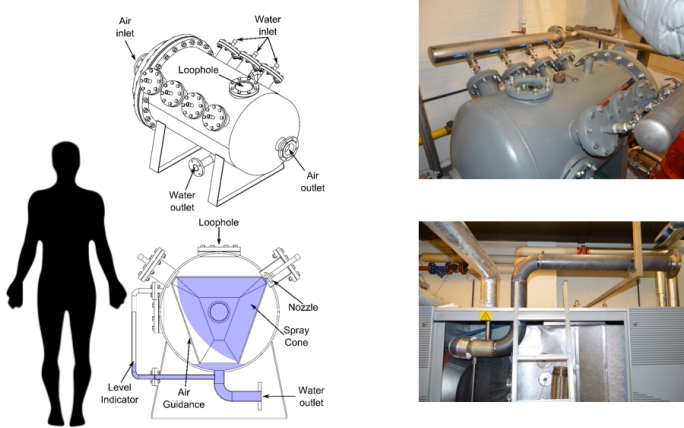

To perform the humidification, a novel saturation tower was developed and integrated into the cycle to saturate the compressed air.

A novel spray saturation tower was developed to saturate the compressed air of the T100 at VUB



The T100 was modified so that the outlet of the compressor was connected to the inlet of the saturator and outlet of saturator to inlet of the recuperator.

Our T100 mGT has been running as an mHAT for the last two years



Preliminary tests focused on
wet start-up procedure
part load, part humidification

By controlling the rotational speed wet and dry efficiencies can be compared

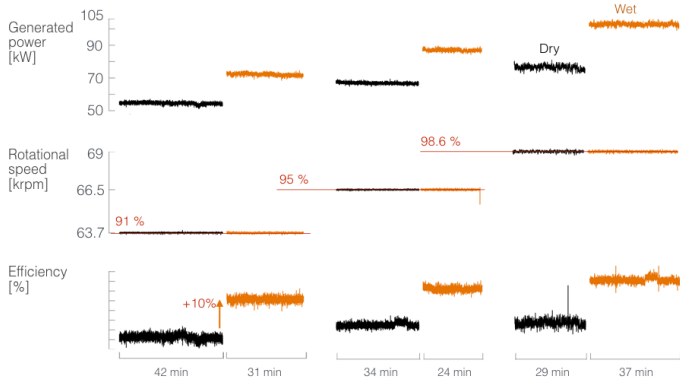

We investigated different aspects of humidification through experiments. In the figure of this slide, we can see the substantial effect of humidification on the generated power and efficiency when keeping the rotation speed constant and for different loads.

Experiments show that water injection results in an electrical efficiency increase

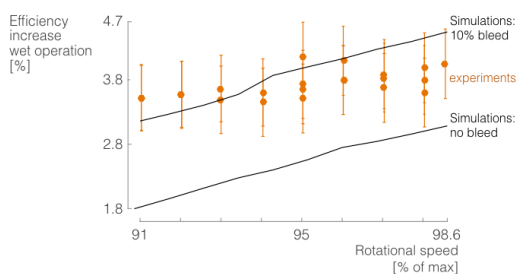

We also compared those results to simulations to get a better insight.

The Sankey diagram of the mGT shows a total mGT efficiency of 86%

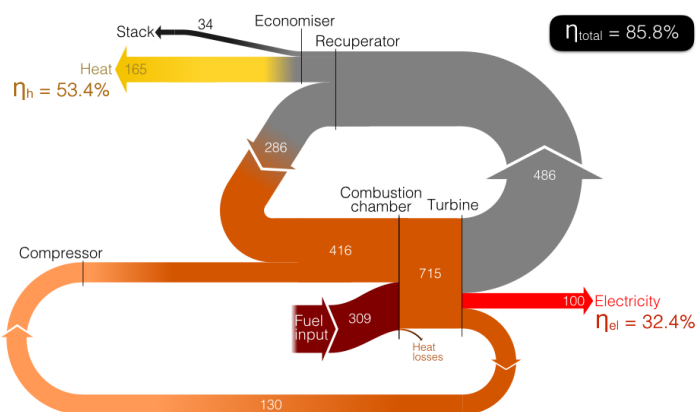

To further understand the flow of energy, we drew the Sankey diagram of the mGT and compared it with the humidified cycle.

With water injection, the electrical efficiency increases from 32.4 to 34.9%

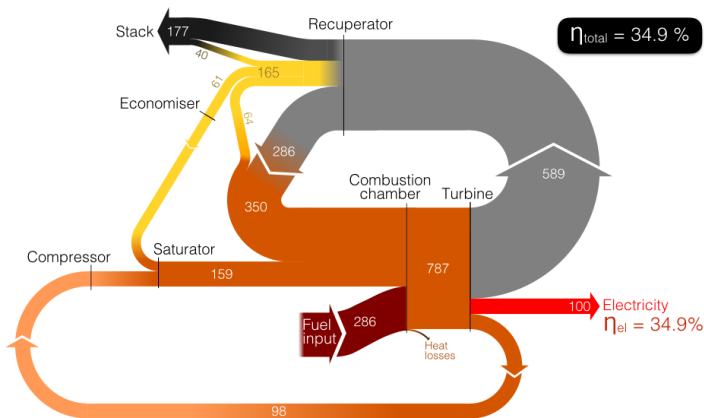

The big difference relies on the recuperation of the heat from the economiser which is not used anymore outside the cycle. The gain mainly relies not only in the saturation tower but also in the recuperator because of the lower temperature of the gas after saturation, hence better heat transfer.

Sankey diagrams do not allow fairly analysing the effect of water injection

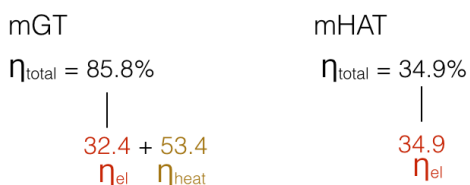

However, using energy flows does not allow a fair comparison between the two cycles because a great part of the CHP efficiency of the mGT configuration comes from heating. Therefore, it gives the feeling that the energy recovery is rather poor, when this is actually not the case.

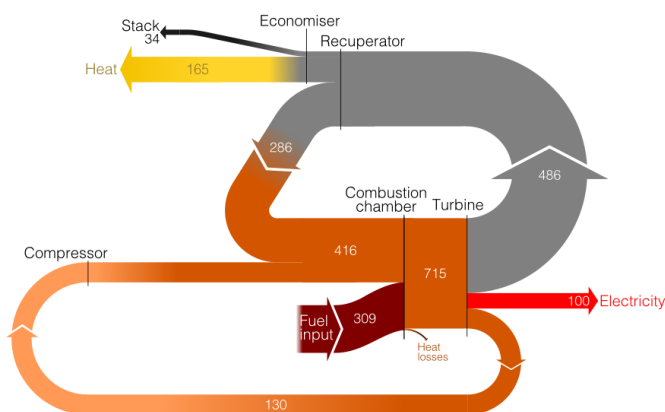

To better analyse this cycle we drew a Grassmann diagram which considers the exergy flows, i.e. useful energy.

Sankey mGT

Grassmann mHAT

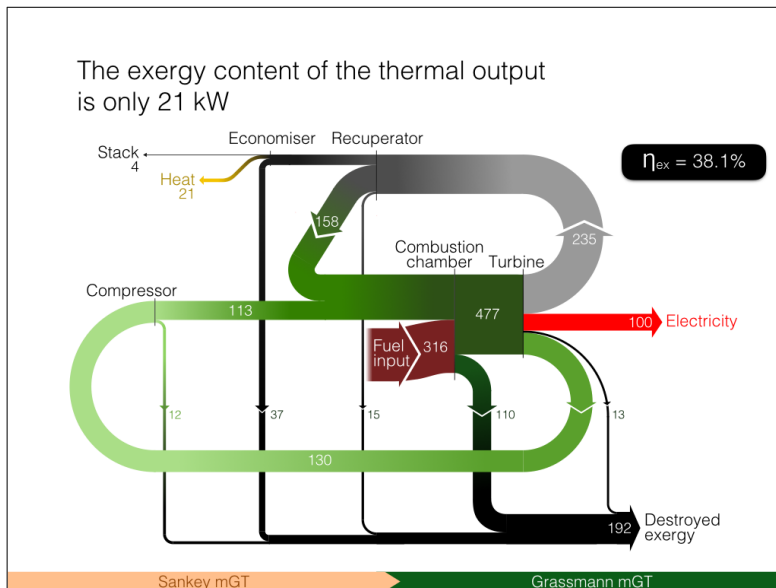

Compared to the Sankey, the Grassmann shows the real energy potential and includes the destroyed exergy. It radically changes the size of the arrow at the economiser as well as the energy in the gases leaving the turbine, while the arrows corresponding to high quality energy (such as electricity and the mechanical energy to drive the compressor) remain the same.

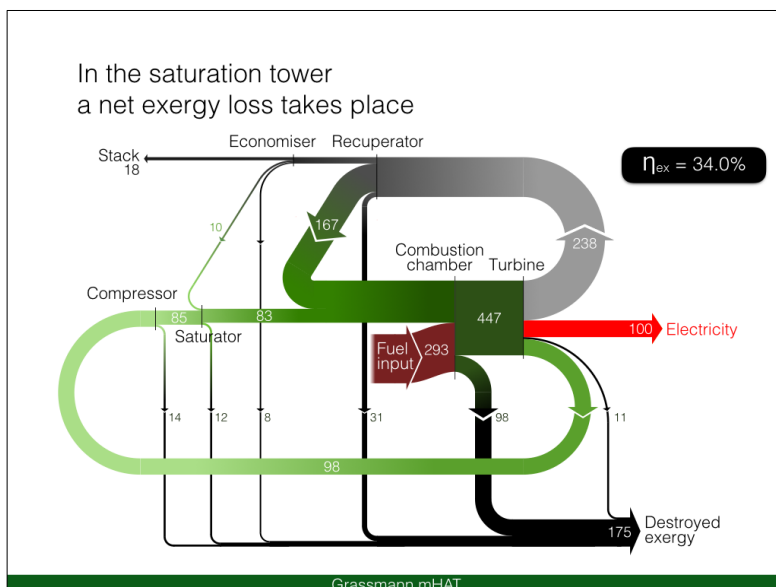

For the humidified cycle, we better understand that most of the exergy gain comes from the recuperator and a lower fuel input.

	mGT	mHAT
1st law	$\eta_{total} = 85.8\%$ $32.4 + 53.4$ $\eta_{el} \quad \eta_{heat}$	$\eta_{total} = 34.9\%$ 34.9 η_{el}
2nd law	$\eta_{total} = 38.1\%$ $31.5 + 6.6$ $\eta_{el} \quad \eta_{heat}$	$\eta_{total} = 34.0\%$ 34.0 η_{el}

The comparison between the original cycle and the humidified cycle using the second law is fairer. We can still appreciate that in CHP mode both the first and second law efficiencies are higher. However, while with the first law it looked like with water injection we decreased the overall efficiency from 86% to 35%. With the second law comparison, we can see how the overall efficiency only decreases from 38% to 34%.

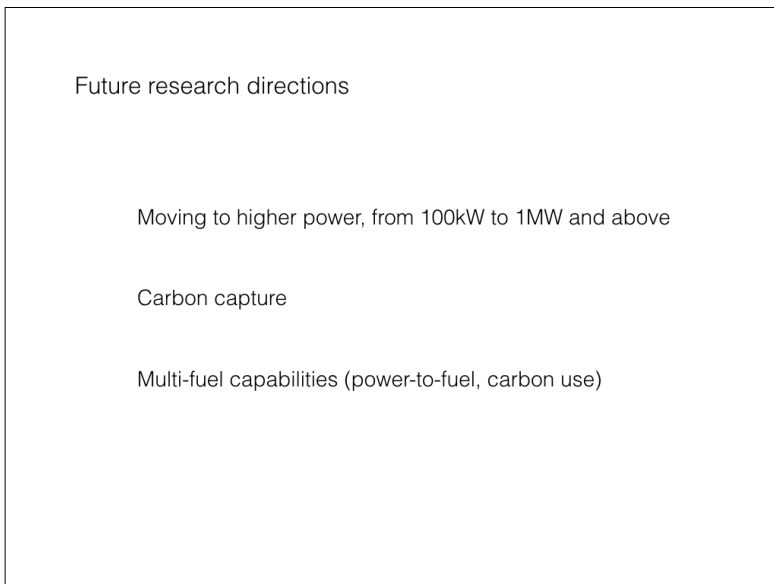
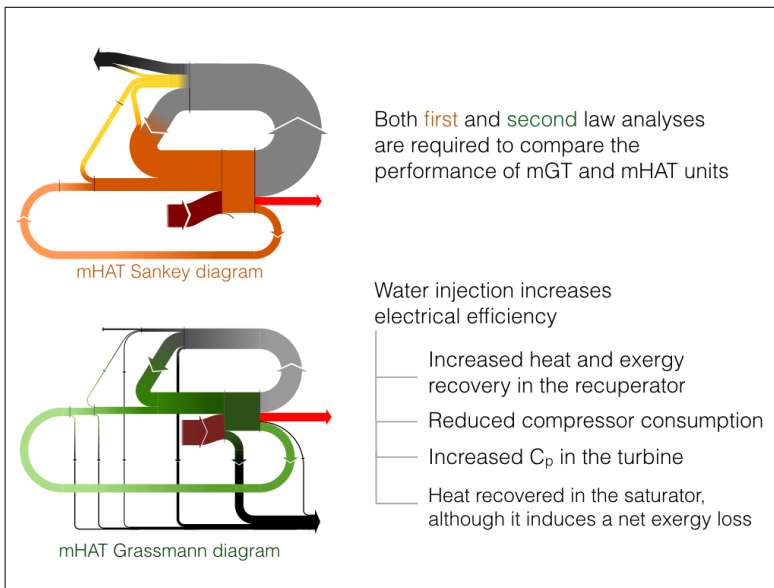

Future research activities will focus on

- Applying humidification to higher power installations, with the major challenge of the need for recuperator;
- Carbon capture, which is very challenging in decentralised applications;
- Multi-fuel capabilities, which is complementary to the carbon capture and can be very useful in the power-to-fuel context.